



RESIN PRESSURE DIGITAL CONTROLLER (HA930 and HA430)

NEW!



FEATURES:

Fast sampling of 40 times per second – Provides 0.025 second sampling cycle to measure and control fast changing processes like pressure.

Numerous functions to improve quality – PV transfer function is activated when switching from MAN (manual) to AUTO (automatic) to keep the ideal RPM which is found at Manual Mode.

Easy zero and span adjustments – Auto-zero and span adjustments are available from the front panel. The span adjustment is accomplished by setting the sensor rated output value (gain setting).

Temperature and Pressure control with a single instrument – The HA930 and HA430 provide dual loop control with a single instrument. The first loop is assigned to a strain gauge input and the second loop to a temperature input (T/C, RTD, and mV/V/mA).

7 inputs and 5 outputs – A maximum of two measured inputs and five event outputs can be specified. A maximum of five outputs can be specified, and various output functions (control output, analog retransmission, event up to 4) can be allocated in output logic operation

Communications – Communication function can be selected from serial communication (RS-232C, RS-422A, RS-485) and Open network (DeviceNet, PROFIBUS).

MINI SA200 CONTROL

Units : mm

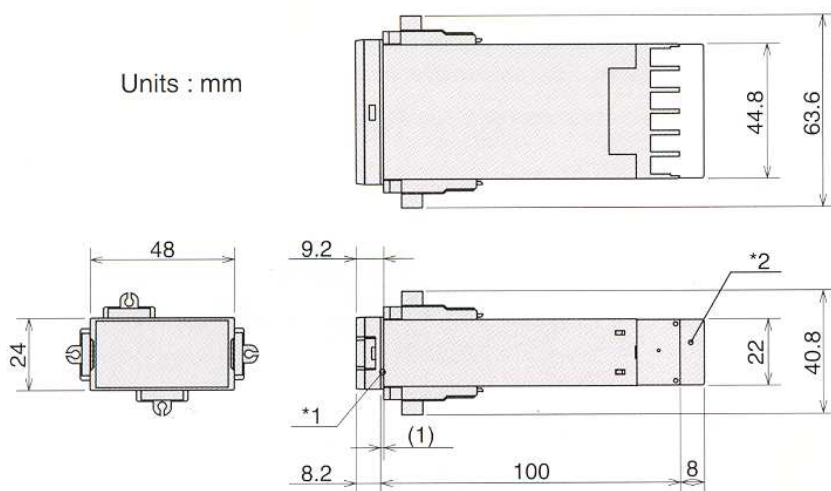

LARGE, BRIGHT LCD DISPLAYS:

- 1/32 DIN size with dual display
- Close vertical and horizontal mounting
- Self-tuning and auto-tuning
- Loop break alarm and temperature alarms
- Digital communications with both temperature MODBUS and RKC protocols
- Water proof and dust protection (rubber packing is added)

*Terminal cover is optional.

For mounting of the SA200, panel thickness must be between 1-10 mm. When mounting multiple SA200s close together, the panel strength should be checked to ensure proper support.

Two mounting brackets will be furnished for installation of the instrument at either the top or bottom or sides.

Close vertically and horizontally mounted instruments cannot be combined in one installation.

WEST HEAT INDUSTRIES LTD

1680 Church Avenue
Winnipeg, Manitoba R2X 2W9
www.westheat.com

ELECTRICAL HEATING DIVISION

Phone: (204) 694-2129
Fax: (204) 694-2098
Fax Orders To: 1-800 358-7711