

MICA BAND HEATERS

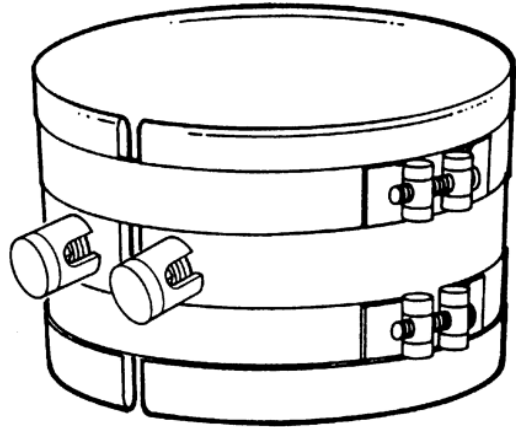

Ceramic Caps
Protects against electrical shock, used with insulated wire. Can be rotated at any angle - screw size 10-24 standard.

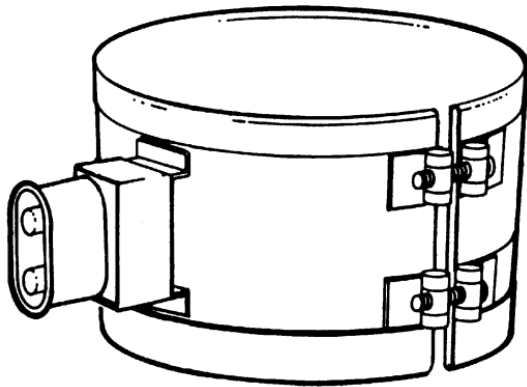

EP - Euro Plug
Quick disconnect cup assembly is a safe way to provide power to heater. Min. width 1 - 1/2", Max. AMPS 15 at 240 volts, Max. volts 240

PARALLEL POST

TANDEM POST

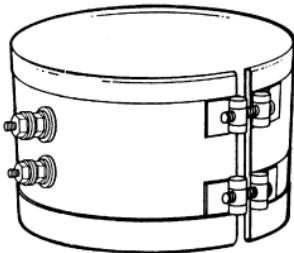

Placed parallel with width of heater, standard on heaters greater than 3" wide.

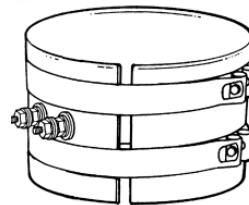

Tandem generally at one end of heater, center line with length of heater. Recommended for narrow heaters.

METAL BRAID

FLEXIBLE LEADS



Metal braid covering single conductor. Recommended for nozzle heating applications where abrasion is a problem. Leads exit each side of gap. 10" metal braid, over 12" fiberglass leads.

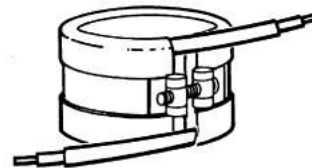

Fiberglass leads exit through ends of heater into gap. Recommended use in areas free of plastic contamination. 10" fiberglass leads.

**Other terminations are available
**Consult local Sales Person

WEST HEAT INDUSTRIES LTD

ELECTRICAL HEATING DIVISION

1680 Church Avenue
Winnipeg, Manitoba R2X 2W9
www.westheat.com

Phone: (204) 694-2129
Fax: (204) 694-2098
Fax Orders To: 1-800 358-7711